

NOTICE
 INFORMATION CONTAINED HEREIN CONSTITUTES PROPRIETARY CONFIDENTIAL AND TRADE SECRET INFORMATION OF OWENS-ILLINOIS, INC., AND IS TO BE ACCEPTED SUBJECT TO THAT UNDERSTANDING. IT IS TO BE KEPT CONFIDENTIAL AND NOT TO BE COPIED, USED OR CONVEYED TO OTHERS WITHOUT OWENS-ILLINOIS' WRITTEN AUTHORIZATION.

DRAWING NO. C-I-75781-01A-00		REV. C
REVISIONS		
	REF C1-26726-1	
A	A1 ADDED SHEET 2	IDT 02-15-02
B	B1 WAS ±.060 B2 REMOVED .407 "H" REF B3 WAS "L" B4 MOVED TO NOTE 4 B5 WAS 84.9 CC / 2.87 FL OZ B6 ADDED NOTE # 4	IDT 03-26-02
C	C1 WAS ±4.0 GRAMS	DPD 5-6-04

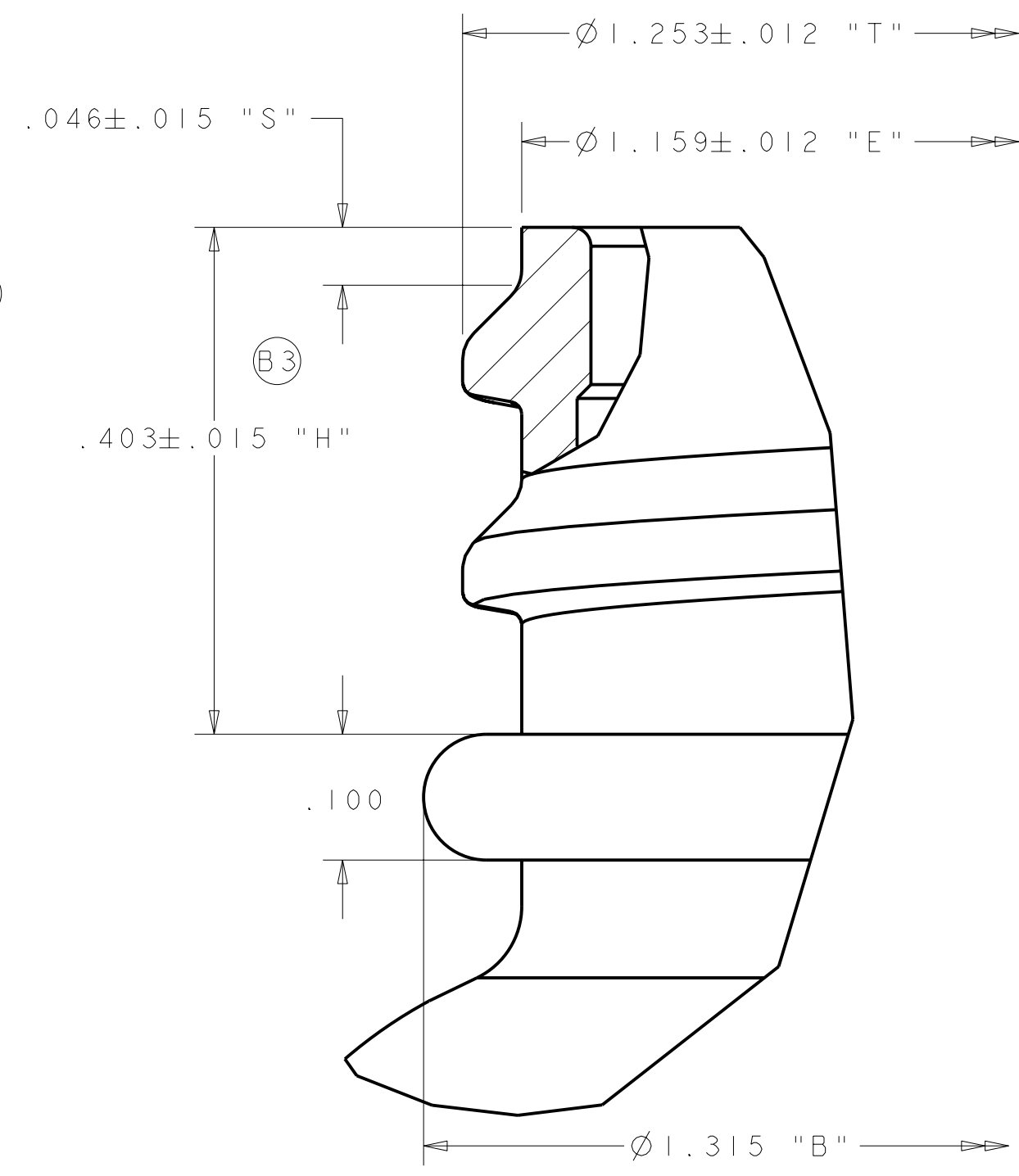

FINISH DETAIL
SCALE 8:1

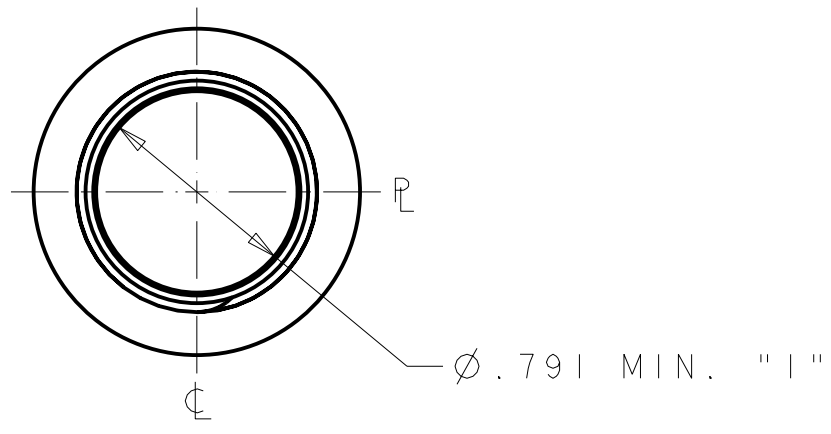
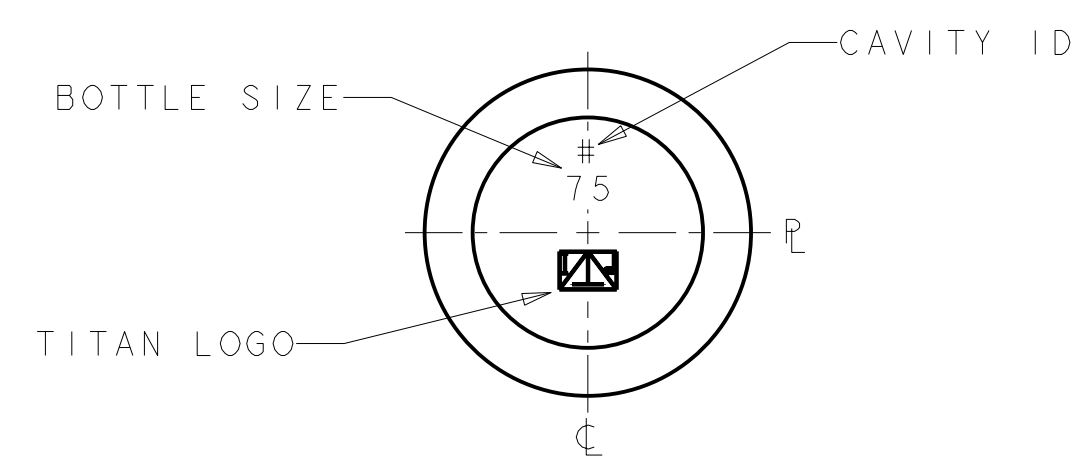
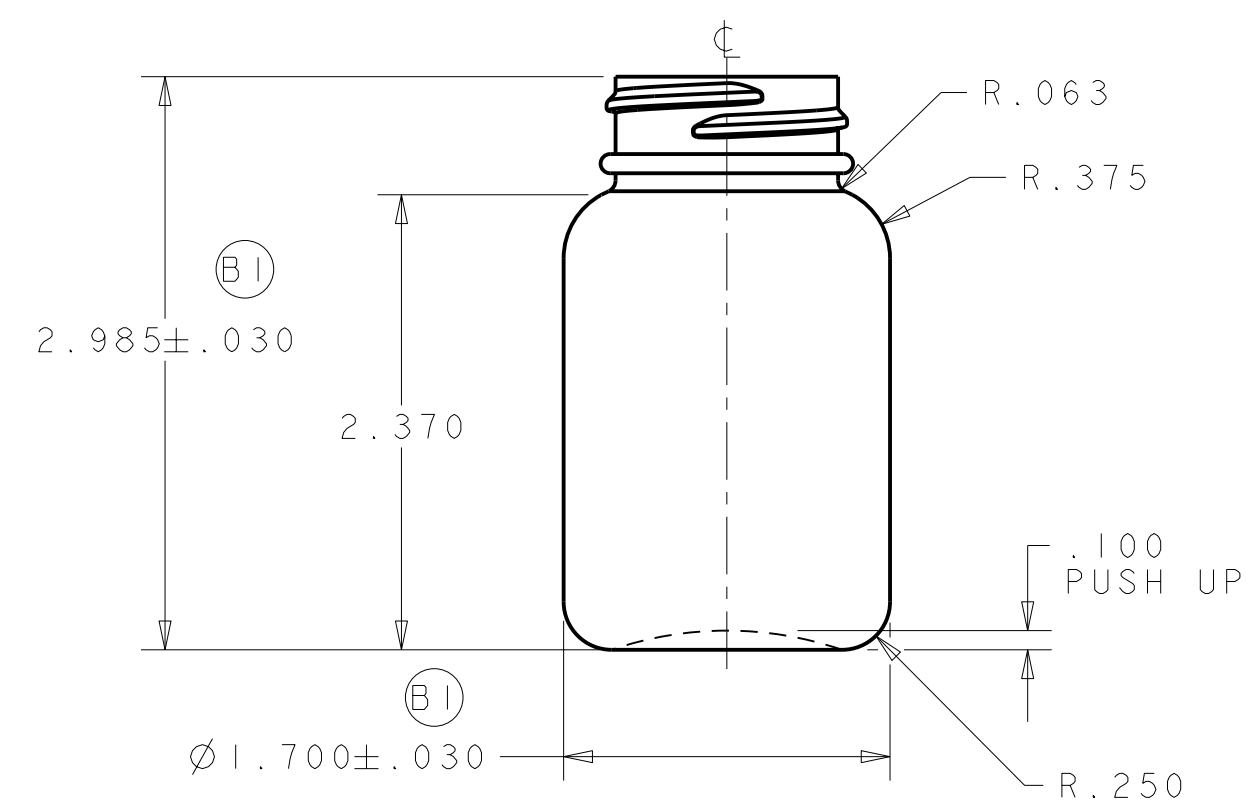

- NOTES:
- 1) NECK FINISH - M33SP400 6 T.P.I. 1 FULL TURN OF THREAD
 - 2) MIN. WALL .015
 - 3) REF. TITAN DWG. # B-05-94-02
 - 4) 10.5 NAT / 10.8 WHT GRAMS±1.0

ALL DIMENSIONS ARE REPRESENTATIVE ONLY! FINAL SIZES TO BE DETERMINED AFTER CONTAINERS ARE MANUFACTURED.

"REFERENCE PRODUCT CENTER FOR CURRENT DRAWING"

**OWENS BROCKWAY
75 CC
WIDE MOUTH ROUND**

DIMENSIONS NOT TOLERANCED ARE PER S.P.I. STANDARDS
 DIMENSIONAL TOLERANCES ±.030 HEIGHT
 UNLESS OTHERWISE SPECIFIED ±.030 BODY
 NOTE: DIMENSIONAL TOLERANCES DO NOT APPLY TO FINISH DIMENSIONS OR TO LOCATION OF FILL POINT

(B4)	HDPE	86.0±4.0 CC 2.91±.14 FL OZ	CC FL OZ
WEIGHT GRAMS	MATERIAL	OVERFLOW AS MOLDED: TREAT ONLY, PAPER LABEL, UV SILKSCREEN, IML, HOT STAMP, PRESSURE SENSITIVE	OVERFLOW AFTER PRE & POST FLAME: HEAT TRANSFER LABEL, SILKSCREEN OVENS
MOLD NO.	DRAWING NO.	REV	
I-75781	C-I-75781-01A-00	C	

PART LIB: CMS	DESIGNER I TRENT & DATE 12-12-01
DESIGN AUTHORIZATION	P.D.E. B MATTISON
OWENS-ILLINOIS Plastics Group Container	

NOTICE
 INFORMATION CONTAINED HEREIN CONSTITUTES PROPRIETARY CONFIDENTIAL AND TRADE SECRET INFORMATION OF TITAN PLASTICS, AND IS TO BE ACCEPTED SUBJECT TO THAT UNDERSTANDING. IT IS TO BE KEPT CONFIDENTIAL AND NOT TO BE COPIED, USED OR CONVEYED TO OTHERS WITHOUT TITAN PLASTICS' WRITTEN AUTHORIZATION.

DRAWING NO. C-11-075-33		REV. C
REVISIONS		
A	A1 ADDED SHEET 2	IDT 02-15-02
B	B1 WAS ±.060 B2 REMOVED .407 "H" REF B3 WAS "L" B4 MOVED TO NOTE 4 B5 WAS 84.9 CC / 2.87 FL OZ B6 ADDED NOTE # 4	IDT 03-26-02
C	C1 WAS ±4.0 GRAMS	DPD 5-6-04

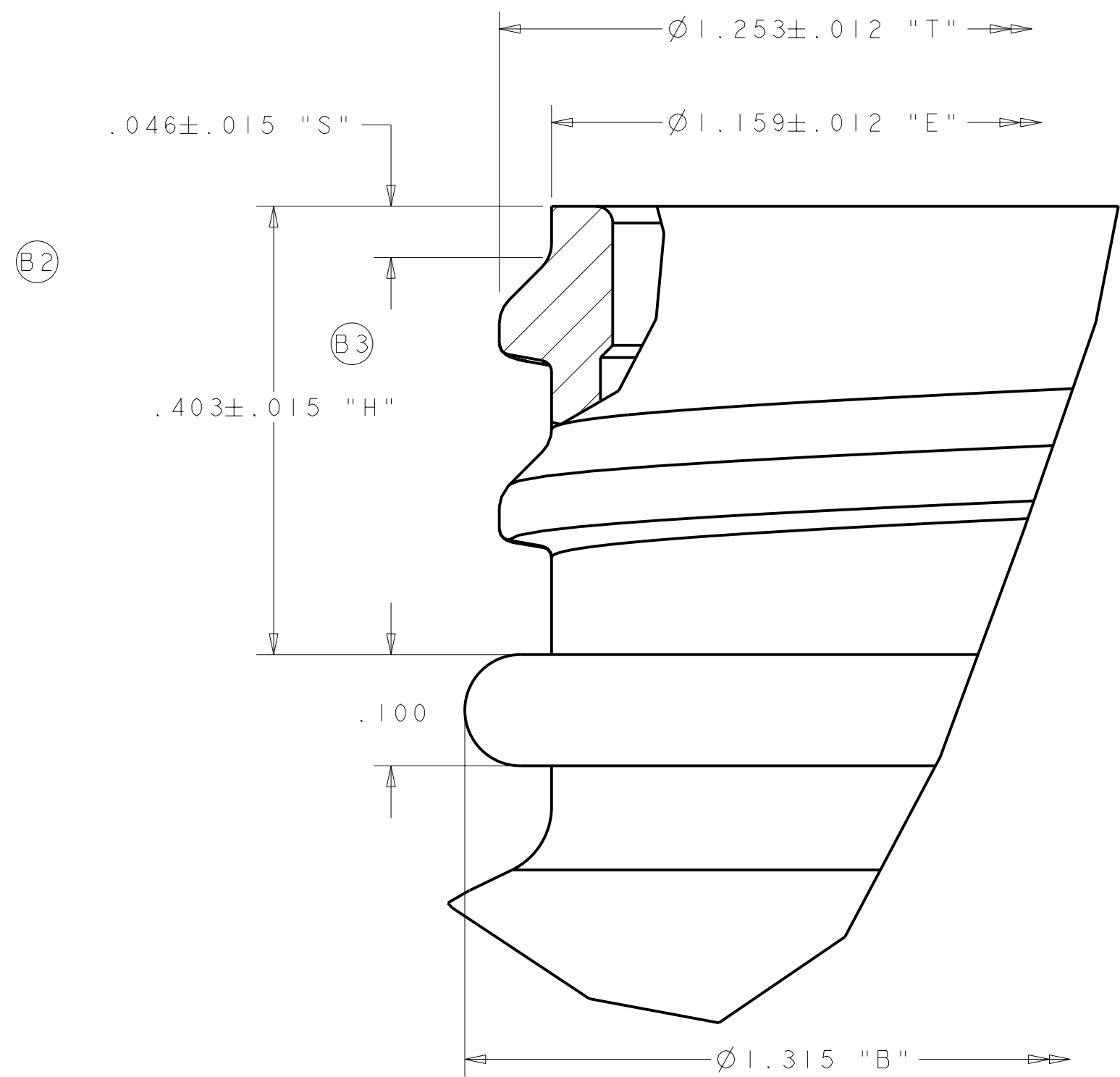
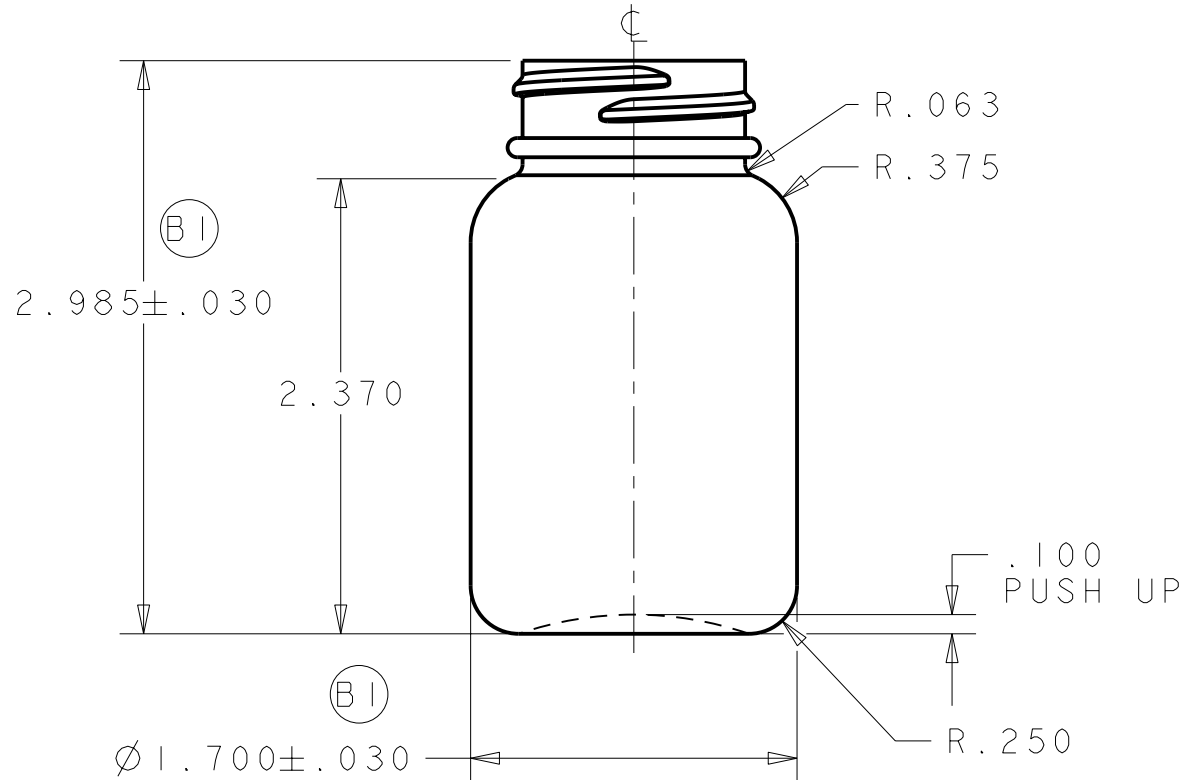
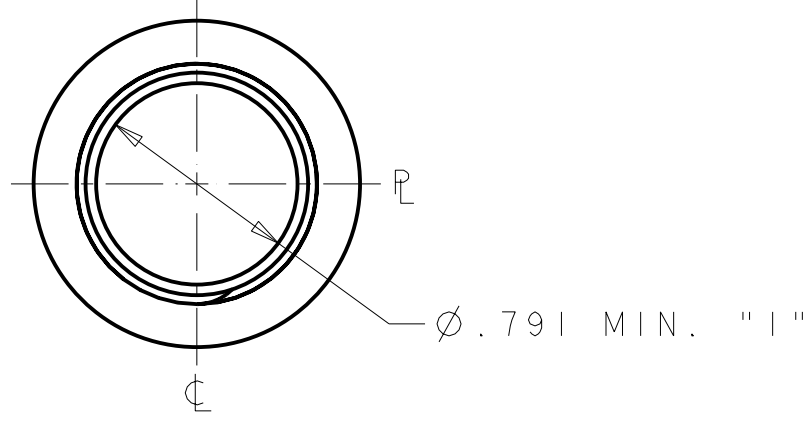

FINISH DETAIL
SCALE 8:1

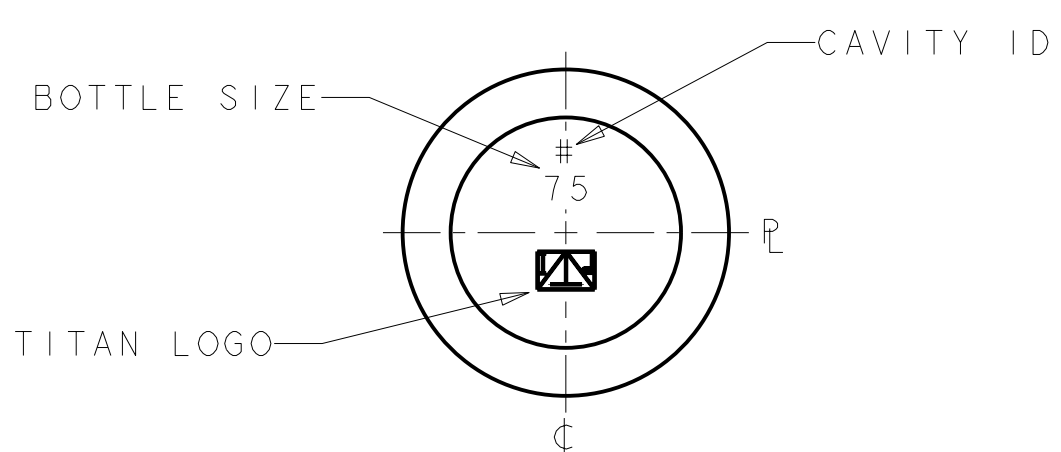

- NOTES:
- 1) NECK FINISH - M33SP400 6 T.P.I. 1 FULL TURN OF THREAD
 - 2) MIN. WALL .015
 - 3) REF. TITAN DWG. # B-05-94-02
 - 4) 10.5 NAT / 10.8 WHT GRAMS±1.0

ALL DIMENSIONS ARE REPRESENTATIVE ONLY! FINAL SIZES TO BE DETERMINED AFTER CONTAINERS ARE MANUFACTURED.

DIMENSIONS NOT TOLERANCED ARE PER S.P.I. STANDARDS
 DIMENSIONAL TOLERANCES ±.030 HEIGHT UNLESS OTHERWISE SPECIFIED ±.030 BODY
 NOTE: DIMENSIONAL TOLERANCES DO NOT APPLY TO FINISH DIMENSIONS OR TO LOCATION OF FILL POINT

HDPE	86.0±4.0 CC 2.91±.14 FL OZ	CC FL OZ
WEIGHT GRAMS	MATERIAL	OVERFLOW AS MOLDED: TREAT ONLY, PAPER LABEL, UV SILKSCREEN, IML, HOT STAMP, PRESSURE SENSITIVE
MATERIAL	OVERFLOW AFTER PRE & POST FLAME: HEAT TRANSFER LABEL, SILKSCREEN OVENS	
MOLD NO. I-75781	DRAWING NO. C-11-075-33	REV. C

**75 ML
WIDE MOUTH ROUND**

PART LIB: CMS	DESIGNER I TRENT & DATE 12-12-01
DESIGN AUTHORIZATION	P.D.E. B MATTISON

TITAN PLASTICS